



MOT Test Number

445232309745

Vehicle Registration Mark

WV08HBG

Vehicle Identification Number

VF7EBRHHK13373399

Make

CITROEN

Model

C8

Colour

Blue

Issuer's Name

D. N. CARTER

Test Class

4

Country of Registration

Great Britain

Expiry Date

20 April 2017 (SEVENTEEN)

Issued

21 Apr 2016

Test Station

7026BG

Odometer Reading and History

21 4 2016: 223565 mi
13 4 2015: 201331 mi
28 3 2014: 169057 mi
25 3 2013: 136918 mi

Inspection Authority

TOP MARQUES
PINHOE TRADING ESTATE
VENNY BRIDGE
PINHOE
EXETER
EX4 8JN
01392464640

Additional Information

To preserve the anniversary of the expiry date, the earliest you can present your vehicle for test is 21 March 2017.

Signature of Issuer

Advisory Information

001 (engine management light illuminated)
002 Brake pipe slightly corroded nearside rear [3.6.B.2c]
003 Brake pipe slightly corroded offside rear [3.6.B.2c]
004 Tyre worn close to the legal limit nearside front (outer edge) [4.1.E.1]
005 Suspension arm rubber bush deteriorated but not resulting in excessive movement nearside front [2.4.G.2]
006 Front wheel bearing has slight play nearside [2.5.A.3c]
007 nearside (slight movement to steering arm)

About this document

- 1 This document is a receipt style certificate telling you that an MOT Test pass result has been recorded in the Driver & Vehicle Standards Agency's (DVSA's) database of MOT Test results; this can be verified at www.gov.uk/check-mot-status.
 - 2 A test certificate relates only to the condition of the components examined at the time of test. It does not confirm the vehicle will remain roadworthy throughout the validity period of the certificate.
 - 3 Check carefully that the details are correct.
 - 4 Whilst advisory items listed above do not constitute MOT failure items, they are drawn to your attention for advice.
 - 5 For further information about this document, please visit www.gov.uk/getting-an-mot or contact DVSA on 0300 123 9000*.
- *Your call may be monitored or recorded for lawful purposes.

TOP ✓ MARQUES

VEHICLE EXAMINATION REPORT

YOUR ATTENTION IS DRAWN TO THE TERMS AND CONDITIONS BELOW

The examination of the vehicle described in this report was of a purely external, visual nature and excludes any dismantling. No responsibility can be accepted for defects not visibly present at the time, or those not detected which fall outside the scope of the examination and (where possible) its limited road test. Road tests, when possible, are conducted for a limited duration and exclude high speed testing.

The accuracy of the instrumentation within the vehicle (speedometer, odometer, fuel and temperature gauges etc.), cannot be verified, neither can the future life expectancy of the clutch and brake linings, or the failure of mechanical components in the future. Statements on fuel and oil consumption levels will also be excluded.

Report No: TOP005	Inspection Date: 20-05-2016
Customer Details Mr. T Goode 21 Venny Bridge Pinhoe Exeter Devon	Inspection Address Top Marques Pinhoe Exeter Devon EX4 8JN
Telephone: 07967 879090	Telephone: 01392 464640

VEHICLE DETAILS

Make & Model	Citroen C8	Registration No.	WV08 HBG
Colour	Blue	Engine CC	1997 Approx.
Vehicle Identity Number. (VIN No.)	VF7EBRHKH13373399		Confirmed Yes
Engine No:			
V5 Registration doc checked	YES	MOT Certificate Expires	20-04-2017
Odometer Reading	224542	Service Records Seen	NO

MECHANIC SUMMARY

PLEASE READ ALL THE PAGES OF THE REPORT

Front nearside tyre close to limit
Recommended to replace both rear brake pipes on the next service.
Front nearside suspension arm rubber showing deterioration.

TOP ✓ MARQUES

EXTERIOR PANELS

KEY:

- A acceptable
- G good
- R repaired
- = scratch
- X dent
- C corrosion
- O chip / rust
- D decals
- P poor condition
- not checked

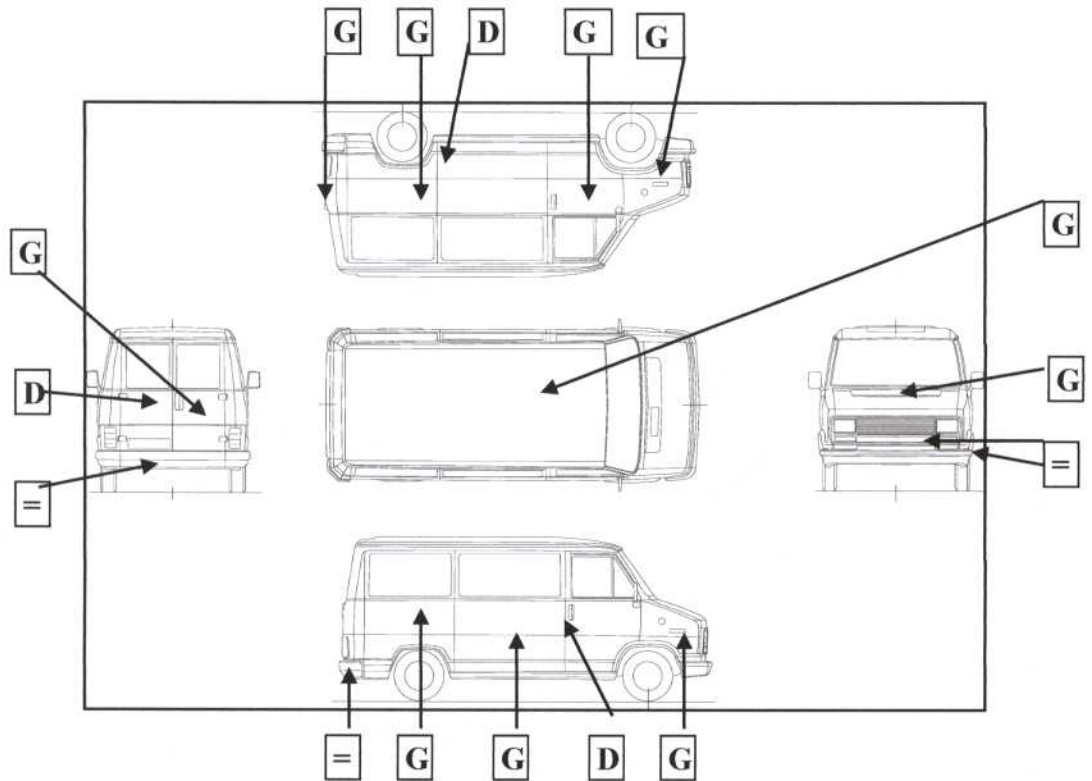

Taxi Colour: Blue

TOP ✓ MARQUES

Minor blemishes, which are acceptable for the vehicle's age and type, are not recorded and you should satisfy yourself in this regard.

EVIDENCE OF BODYWORK REPAIRS **NO** No Major Repairs seen

Comments

Vehicle has small marks on rear door panel, bumper, passenger ¼ panel and front bumper.

KEY FOR POINTS ON FOLLOWING PAGES

- S** **Satisfactory for age and recorded mileage**
- **Could not be checked**
- x** **Needs immediate attention**
- A** **Advisable repair**
- N/A** **Not applicable**
- Y** **Yes**
- N** **No**
- C** **See Engineer's comments**

BODY EXTERIOR

1. Panel Condition/Alignment	S	5. Bumpers No plates – F/R	S	9. Body damage	Y
2. Paintwork	S	6. Door locks – operation	S	10. Corrosion	N
3. Exterior trim	S	7. Fuel filler cover and cap	S	11. Mud flaps None Fitted	N/A
4. Glass	S	8. Elevating Roof (operation/cond..)	N/A	12.	

ENGINE COMPARTMENT Diesel

13. Coolant Level/Condition	S	21. Clutch Fluid	S	29. Accelerator linkage	S
14. Coolant leaks	N	22. Brake Fluid	S	30. Body panels	S
15. Antifreeze	S	23. Engine Oil level	S	31. Bonnet catch	S
16. Radiator/Cap	S	24. External leaks (engine)	NO	32. Bonnet hinges	S
17. Hoses/Pipes	S	25. Engine mountings	S	33. Cold starting	S
18. Drive Belts	S	26. Fuel Injection	S	34. Fast idle (cold)	S
19. Water Pump	S	27. Turbocharger	S	35. Noise level (cold)	S
20. Power Steering	S	28. Fuel pump/Pipes	S	36. Excess fumes/smoke	NO

Spark plugs, Injectors or Glow Plugs are not removed.

It should be noted that a gas analyser has not been used to check exhaust emissions.

If no documentation is seen indicating camshaft drive belt replacement, to ensure future serviceability, it is important that the belt is replaced immediately and then at intervals specified by the manufacturer. It is in your best interests that you ensure that this is carried out.

TOP ✓ MARQUES

ELECTRICAL / CONTROLS					
37. Starting system/Ignition lock	S	43. Stop lights	S	51. Horn	S
38. Battery charging system	S	44. Indicator/Hazard lights	S	52. Radio/Cass./CD/Aerial	X
39. Voltages at battery:	S	45. Reverse / Fog lights	S	53. Heater(s) / Fan controls	S
normal	S	46. Auxiliary lights	S	54. Air Con operation	S
charging	S	47. Interior / Panel lights	S	55. Door locking	S
40. Headlights	S	48. Screen dimisters SELECT	S	56. Windows	S
41. Sidelights /Running lights	S	49. Mirrors (electric)	S	57. Wipers/Washers	S
42. Rear and No. plate lights	S	50. Controls/Instruments	S	58. Headlamp washers	N/A

INTERIOR / LUGGAGE COMPARTMENT					
59. Steering Wheel/Adjustment	S	66. Door seals /hinges	S	73. Rear parcel shelf/blind	S
60. Seat upholstery – F/R	S	67. Interior sills	S	74. Boot/tailgate lock	S
61. Seat adjustment	S	68. Headlining/visors	S	75. Luggage/Load area trim con	S
62. Seatbelts – F/R	S	69. Sun roof(s) Elec.	N/A	76. Illumination light	S
63. Carpets – F/R	S	70. Dash panel (condition)	S	77. Tool kit etc	S
64. Door trim panels	S	71. Cigarette lighter(s)	N/A	78. Living Area (Visual Only)	N/A
65. Door fitting /operation	S	72. Mirrors (internal)	S	79.	

FRONT SUSPENSION / STEERING / UNDERFRAME					
80. Engine underside leakage	NO	85. Wheel hubs/bearings	A	90. Sub-frames/mountings	S
81. Steering joints/ball joints	S	86. Springs/suspension units	A	91. Suspension arms/mountings/joint	S
82. Steering Rack and Pinion	S	87. Sphers/Pipes/Hoses	N/A	92. Tie bars/anti roll bars	S
83. Chassis members	S	88. Dampers (condition / leaks)	S	93. Corrosion protection	S
84. Power steering Hydraulic	S	89. Power steering pipes/gaiters	S	94. Corrosion – floor/chassis	NO

REAR SUSPENSION / UNDERFRAME					
95. Springs/suspension bars	S	99. Location rods/fixings	S	103. Sub-frames/mountings/axles	S
96. Anti roll bar	S	100. Bump stops/gaiters	S	104. Chassis members	S
97. Dampers/bushes	S	101. Wheel hubs/bearings	S	105. Corrosion protection	S
98. Suspension arms/fixings	S	102. Spheres/Pipes/Hoses	N/A	106. Corrosion – floor/chassis	NO

CLUTCH / TRANSMISSION Manual					
107. Fluid/Oil leaks	NO	111. Casings/Axles/Differential(s)	S	115. Backlash	S
108. Cables/adjustments	S	112. Mountings	S	116. Gaiters	S
109. Hydraulic system	S	113. Drive shaft assembly	S	117. Propeller shaft(s)	N/A
110. Linkage (wear)	S	114. Universal/sliding joints	S	118. Prop. Bearings/Supports	N/A

EXHAUST SYSTEM					
119. Manifold(s)	S	121. Silencer(s)/Catalyst(s)	S	123. Joints/Couplings	S
120. Pipes	A	122. Heat shields/Mountings	S	124. System condition	S

FUEL SYTEM					
125. Tank	S	127. Fuel lines	S	129. Evidence of leaks	NO
126. Tank fixings	S	128. Breather pipes	S	130.	N/A

TOP ✓ MARQUES

BRAKES					
131. Master cylinder security	S	134. Flexible hoses	S	137. Hand/Parkbrake op/adjustment	S
132. Fluid leaks	N	135. Pipes/Connections	S	138. Hand/Parkbrake linkage	S
133. Servo/Power system	S	136. Discs/Pads/Drums	S	139. Pedal/Linkage	S

WHEELS AND TYRES Type					
140. Wheel Rims	S	Alloy Wheels			
141. Wheel Trims	N/A				
Tyres	Make	Size	Type / Construction	Min tread depth	
142. RH Front	Raggiori	215/60/16	Radial/Tubeless	4-5mm	S
143. LH Front	Ecosis	215/60/16	Radial/Tubeless	2-3mm	S
144. RH Rear	Raggiori	215/60/16	Radial/Tubeless	8-9mm	S
145. LH Rear	Btc	215/60/16	Radial/Tubeless	8-9mm	S
146.					
147.					
148. Spare	Not checked				

ROAD TEST		
Finish Odom. Reading	224555	Conditions Day
Test Duration	12.5 Miles	Speed achieved up to 70 MPH

149. Final drive op./Noise level	S	156. Instrument/Controls function	S	163. Road holding/Stability	S
150. Gearbox operation/noise level	S	157. Steering wheel alignment	S	164. General steering/Handling	S
151. Engine performance	S	158. Clutch operation	S	165. Footbrake operation	S
152. Engine noise	S	159. 4WD operation	N/A	166. Hand/Parkbrake operation	S
153. Excess smoke	NO	160. Cooling fan operation	--	167. Suspension noise	N
154. Overheating evidence	NO	161. Steering effort	S	168. Warning lights	S
155. Auto changes/Kickdown/Inhib.	N/A	162. Hot restarting	S	169.	

FINAL CHECK					
170. Oil leaks	NO	171. Coolant leaks	NO	172.	

Please read all pages of this report

TOP ✓ MARQUES

Essential & Desirable Repairs

It is strongly advised that the essential defects are investigated immediately or rectified prior to purchase of the vehicle and desirable repairs are carried out in the near future. Some defects may prove costly to rectify and this must be considered prior to purchase or authorising any remedial work.

Attention

Some vehicles are provided with a master key, which can be extremely costly to replace (sometimes in excess of £1000) as, in some cases, if the master key is missing the Engine Control Unit (ECU) may have to be replaced should you encounter problems. As well as this, some radios have codes to allow them to operate. Please satisfy yourself that you have all relevant keys and codes. You should also ensure you are given all relevant instruction manuals for the vehicle, radio, alarm and immobilisers as necessary

Item	Defect/Item requiring further investigation /rectification	D/X

Report Ref: TOP005	Reg. No: WV08 HBG	Signed: 	Mechanics Name: Dave Carter	Date: 20-05-2016
------------------------------	-----------------------------	---	---------------------------------------	----------------------------